

2099-1004-21L Source, Splitter, Inserter, Switch

The 2099-1004-21L Source, Splitter, Inserter, Switch is a 10 MHz, ± 0.01 ppm oven controlled crystal oscillator (OCXO) with way splitter and circuitry to insert the 10MHz signal and DC voltage on L-band output following a 1:1 L-band Switch. The L-band switch provides Auto, Manual or Remote relay switching between CH1 and CH2, 0.95-2.15 GHz input signals to one output. In AUTO, the L-band output is determined by the external contact closure alarms of the two channels. In AUTO, the L-band switches from CH1 to CH2 only if CH1 alarms and CH2 is good. Latched switches minimize switching when power is cycled. LEDs indicate CH1 and CH2 external L-band alarms, Remote mode (yellow), and redundant power supplies on (green). Multi-function switches select Auto, Local, or Remote operation and the Manual mode signal path. Remote operation via the RS232/RS485 M&C (ethernet option -W8) selects CH1 or CH2 and indicates switch position and alarm status. A contact closure indicates if either or both CH1, CH2 are in alarm.

The 10 MHz signal inserted on the L-band output and out of the 4-way splitter is the internal OCXO which can lock to an external 10 MHz reference either manually (EXT) or automatically (AUTO). In AUTO, the 2099-1004-21L switches from External to Internal only if the external 10 MHz level drop below -6 dBm. The unit switches back when the external 10 MHz signal then goes above a -3 dBm level. Multi-function switches select Internal (INT), External (EXT), or Automatic (AUTO) locking to the external 10 MHz reference. Remote operation via the RS232/RS485 M&C interface allows selection of INT, EXT, or AUTO and indicates mode selection and alarm status. An LCD display shows INT, EXT, or AUTO operation and if the 10 MHz signal is locked to the external reference. Connectors are BNC, female for the L-band and 10 MHz signals and DB9 for M&C and for the alarm contact closure I/Os. The 2099-1004-21L is a 1RU chassis with redundant power supplies fed by separate fused 100-240 $\pm 10\%$ VAC AC input connectors.

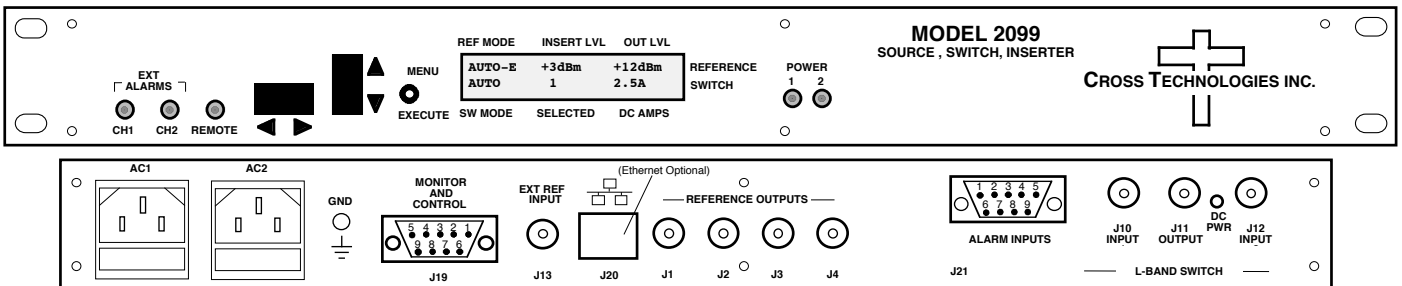

2099-1004-25L FRONT AND REAR PANEL

2099-1004-25L Technical Specifications

L-Band Switch Characteristics (0.95 to 2.15 GHz)

| | |
|------------------------|--|
| Impedance/RL | 50 ohms/ 10dB min., 12 dB typ. |
| Insertion Loss | 2.5 dB max., ≤ 1.5 dB, typ. Isolation |
| Frequency Response, dB | ± 1.5 , 950 - 2150 MHz; ± 0.5 , 36 |
| Isolation | -45 dB max., ≤ -55 dB, typ. |
| Switch time | ≤ 100 milliseconds |

External 10 MHz Input Characteristics

| | |
|-------------------------|--|
| Impedance/RL | 50 Ω /75 Ω , >16 dB |
| Level, nominal | +3 dBm ± 3 dB |
| Level, Auto Switch, dBm | Int $>$ Ext. -6 ± 2 dB; Ext $>$ Int. -2 ± 2 dB |

Internal 10 MHz OCXO (Over temp)

| | |
|-----------------------------|---|
| Level, adjustable (int ref) | -7 dBm to +13 dBm |
| Stability, Aging, Warm up | ± 0.01 ppm; ± 0.001 ppm per day; ± 0.1 ppm per year; ± 0.01 ppm in 1 hour |
| Phase Noise (dBc/Hz) | ≤ -110 @ 10Hz; ≤ -140 @ 100Hz; ≤ -150 @ 1kHz; ≤ -155 @ 10kHz |
| Manual Select Status | M&C serial |

Controls, Indicators, Connectors, Other

| | |
|--------------------------|--|
| Mode Select | Local/Remote, Auto/Manual - push-button switches, or remote selection; LCD Display |
| Pwr, Remote, L-Alarm LED | Green LEDs, (PS1, PS2), Yellow LED & M&C serial, Red LED & M&C serial |
| Alarm Status | Red LEDs, External Form C contact closure, M&C serial |
| Alarm I/Os, M&C Conn. | DB9 (female), DB9 (female); Ethernet Option -W8 |
| DC Power Insertion | +24 ± 2 VDC, 2.5 A, max.; M&C and LCD display of current |
| DC Power Insert Fuse | Resettable Fuse trips at 3 ± 0.3 Amps |
| Conn; 10 MHz In; L-band | BNC, female; 75 ohm, 50 ohm |
| Size | 1 RU, 19 inch standard chassis 1.75" high X 16.0" deep |
| Power | Redundant 100 - 240 $\pm 10\%$ VAC, 47 - 63 Hz, 120 W max. power supplies |

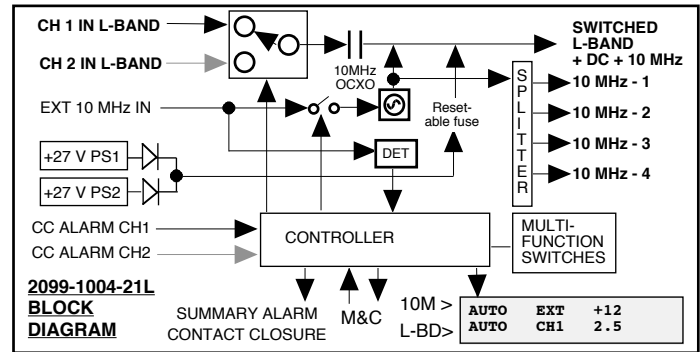

*10°C to 40°C; Specifications subject to change without notice